

| BASE SIZE | SEAL TYPE | NUMBER OF PORTS | ACTUATION TYPE | ORDERING NUMBER |
|-----------|-----------|-----------------|----------------|---------------------|
| 1.125" | C-SEAL | 2-PORTS | HYBRID LOTO | MDV-18-1-2-07-X-X-X |
| | | 3-PORTS | | MDV-18-1-3-07-X-X-X |

SEAT MATERIAL DESIGNATORS

- K = PCTFE (KEL-F®)
- V = VESPEL®
- P = PEEK™
- F = PFA / ASTM D3307, TYPE II

MATERIAL DESIGNATORS

- S = 316L SST SEMI F20
- A = 316L
- N = NICKEL 200
- M = NICKEL 400
- H = NICKEL ALLOY C22

PURITY DESIGNATORS

- S = STANDARD FINISH
- H = HIGH PURITY
- U = ULTRA-HIGH PURITY

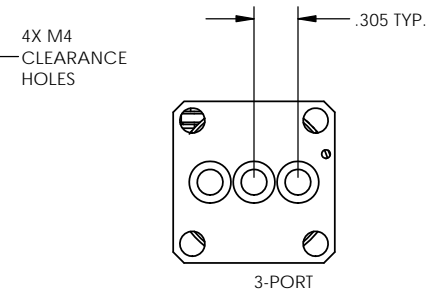
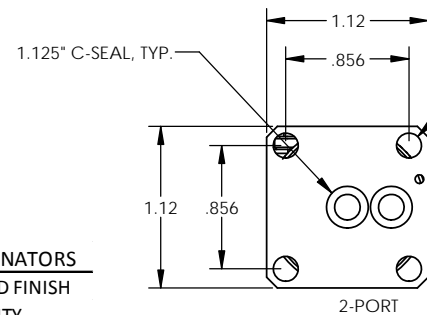
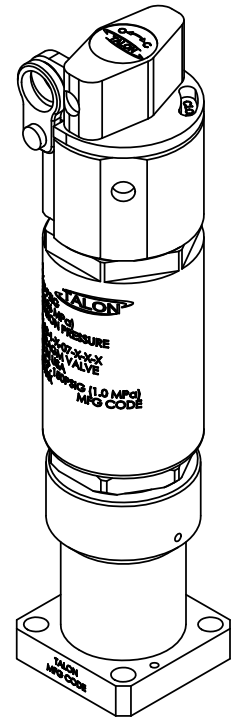
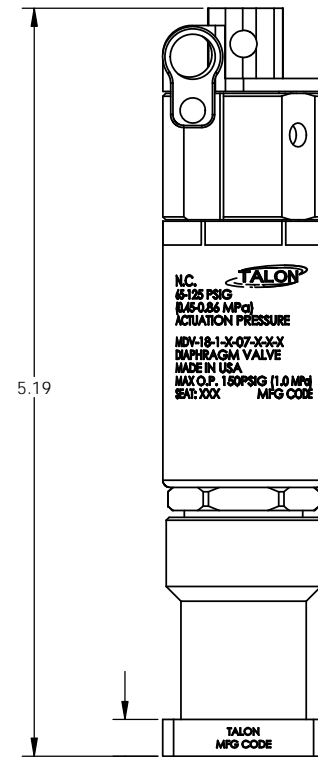

NOTES:
 1. DRAWINGS FOR SPECIFICATION PURPOSES AND ARE FOR REFERENCE ONLY.
 2. ALL VERSIONS OF THE DRAWING ARE SUPERSEDED BY THIS RELEASE AND SUBJECT TO CHANGE WITHOUT NOTIFICATION.

| | | | | |
|---|--|-------------------------------|--|--|
| EFFECTIVE DATE: 12/17/2018 | | INNOVATION WITH PRECISION | 1003 INDUSTRIAL DRIVE SAUK RAPIDS, MN 56379 VOICE: 320-251-0390 FAX: 320-251-5810 | |
| INTERPRET DRAWING PER: ASME Y14.5 - 2009 | | | DESCRIPTION: MDV, 1.125" C-SEAL, HYBRID LOTO | |
| THIRD ANGLE PROJECTION: | | | SIZE: C | PART NUMBER: MDV-18-1-X-07-X-X-X |
| PROPRIETARY AND CONFIDENTIAL THE INFORMATION CONTAINED IN THIS DRAWING IS THE SOLE PROPERTY OF TALON INNOVATIONS, INC. ANY REPRODUCTION IN PART OR AS A WHOLE WITHOUT THE WRITTEN PERMISSION OF TALON INNOVATIONS, INC. IS PROHIBITED. | | SCALE: 3:2 | SHEET 1 OF 1 | |
| DO NOT SCALE DRAWING | | | | |