

BASE SIZE	SEAL TYPE	NUMBER OF PORTS	ACTUATION TYPE	ORDERING NUMBER
1.125"	W-SEAL	2-PORTS	MANUALLY OPERATED	MDV-18-2-2-01-X-X-X
		3-PORTS		MDV-18-2-3-01-X-X-X

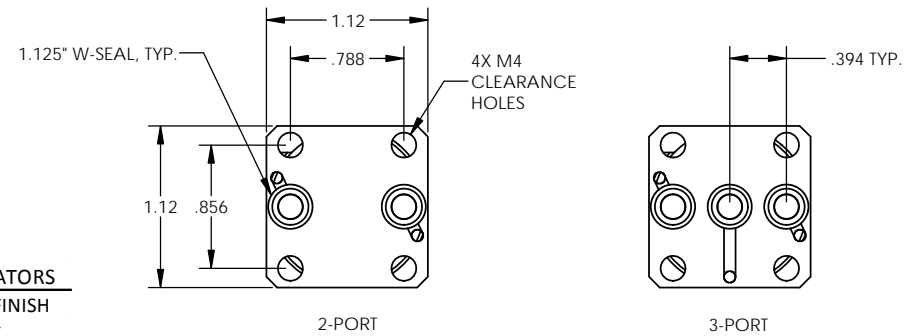
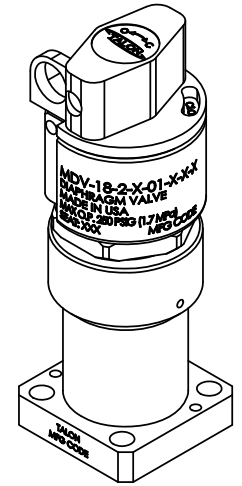
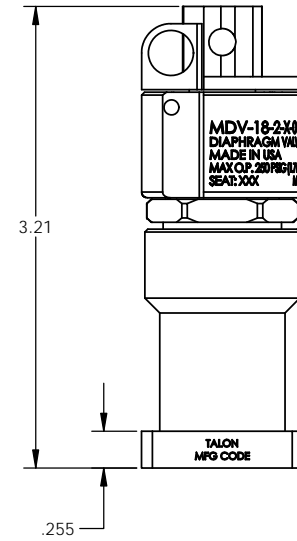

SEAT MATERIAL DESIGNATORS

K = PCTFE (KEL-F®)
 V = VESPEL®
 P = PEEK™
 F = PFA / ASTM D3307, TYPE II

MATERIAL DESIGNATORS

S = 316L SST SEMI F20
 A = 316L
 N = NICKEL 200
 M = NICKEL 400
 H = NICKEL ALLOY C22

PURITY DESIGNATORS

S = STANDARD FINISH
 H = HIGH PURITY
 U = ULTRA-HIGH PURITY

NOTES:
 1. DRAWINGS FOR SPECIFICATION PURPOSES AND ARE FOR REFERENCE ONLY.
 2. ALL VERSIONS OF THE DRAWING ARE SUPERSEDED BY THIS RELEASE AND SUBJECT TO CHANGE WITHOUT NOTIFICATION.

EFFECTIVE DATE: 2/6/2017	<p>1003 INDUSTRIAL DRIVE SAUK RAPIDS, MN 56379 VOICE: 320-251-0390 FAX: 320-251-5810</p>				
INTERPRET DRAWING PER: ASME Y14.5 - 2009					
THIRD ANGLE PROJECTION					
PROPRIETARY AND CONFIDENTIAL THE INFORMATION CONTAINED IN THIS DRAWING IS THE SOLE PROPERTY OF TALON INNOVATIONS, INC. ANY REPRODUCTION IN PART OR AS A WHOLE WITHOUT THE WRITTEN PERMISSION OF TALON INNOVATIONS, INC. IS PROHIBITED.	DESCRIPTION: MDV, 1.125" W-SEAL, MANUALLY OPERATED				
DO NOT SCALE DRAWING	<table border="1"> <tr> <td>SIZE C</td> <td>PART NUMBER: MDV-18-2-X-01-X-X-X</td> </tr> <tr> <td>SCALE: 3:2</td> <td>SHEET 1 OF 1</td> </tr> </table>	SIZE C	PART NUMBER: MDV-18-2-X-01-X-X-X	SCALE: 3:2	SHEET 1 OF 1
SIZE C	PART NUMBER: MDV-18-2-X-01-X-X-X				
SCALE: 3:2	SHEET 1 OF 1				