

BASE SIZE	SEAL TYPE	NUMBER OF PORTS	ACTUATION TYPE	ORDERING NUMBER
1.500"	W-SEAL	2-PORTS	PNEUMATIC N.O.	MDV-24-2-2-04-X-X-X
		3-PORTS		MDV-24-2-3-04-X-X-X

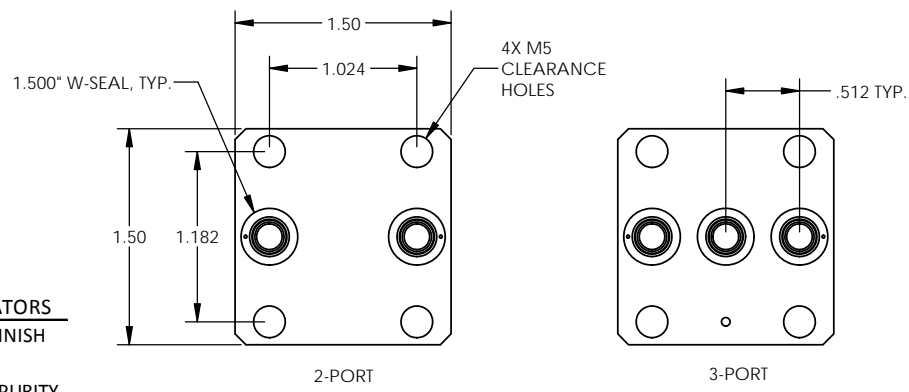

SEAT MATERIAL DESIGNATORS

- K = PCTFE (KEL-F®)
- V = VESPEL®
- P = PEEK™
- F = PFA / ASTM D3307, TYPE II

MATERIAL DESIGNATORS

- S = 316L SST SEMI F20
- A = 316L
- N = NICKEL 200
- M = NICKEL 400
- H = NICKEL ALLOY C22

PURITY DESIGNATORS

- S = STANDARD FINISH
- H = HIGH PURITY
- U = ULTRA-HIGH PURITY

NOTES:
 1. DRAWINGS FOR SPECIFICATION PURPOSES AND ARE FOR REFERENCE ONLY.
 2. ALL VERSIONS OF THE DRAWING ARE SUPERSEDED BY THIS RELEASE AND SUBJECT TO CHANGE WITHOUT NOTIFICATION.

EFFECTIVE DATE: 2/6/2017		 INNOVATION WITH PRECISION 1003 INDUSTRIAL DRIVE SAUK RAPIDS, MN 56379 VOICE: 320-251-0390 FAX: 320-251-5810
INTERPRET DRAWING PER: ASME Y14.5-2009		
THIRD ANGLE PROJECTION		
PROPRIETARY AND CONFIDENTIAL THE INFORMATION CONTAINED IN THIS DRAWING IS THE SOLE PROPERTY OF TALON INNOVATIONS, INC. ANY REPRODUCTION IN PART OR AS A WHOLE WITHOUT THE WRITTEN PERMISSION OF TALON INNOVATIONS, INC. IS PROHIBITED.		DESCRIPTION: MDV, 1.500" W-SEAL, PNEUMATIC N.O.
SIZE: C	PART NUMBER: MDV-24-2-X-04-X-X-X	
DO NOT SCALE DRAWING		SCALE: 3:2
		SHEET 1 OF 1